



STOP THEFT  
BEFORE  
IT HAPPENS



The history of **MLS** begins in 1993 with the mechanical anti-theft device, initially called Meck Lock System. In 2009, following innovative improvements to the system, *Dario Bartesaghi* (CEO) obtains a new Industrial Invention European Patent and formed the company **Mechanical Line Solutions Srl**.

Mechanical Line Solutions stands as a qualified player committed to face and solve, with technologically advanced solutions, customers' vehicles and equipment security needs, with a single objective: **stop theft before it happens.**

With a wealth of commercial, innovative and technical experience, Mechanical Line Solutions offers a wide range of systems to anyone who wishes to secure their vehicles and equipment against theft.

Mechanical Line Solutions offers competence, quality of installation and timeliness in technical assistance, fundamental elements for obtaining efficient systems that last over time, which are able to promptly communicate the event upon the occurrence of an alarm condition.

Theft is a widespread problem in all sectors, especially when considering vehicles intended for commercial use, such as excavators, wheel loaders, telehandlers, rollers, backhoe loaders and tractors. Today, **protecting your vehicles against theft is essential**, using sophisticated mechanical and technological solutions.

**MLS W 020**

**GYROTRACTOR**

**CAP ALARM**



**SAT PLUS  
TRACK ME PLUS  
ITRACK ME**

# MECHANICAL HYDRAULIC ANTI-THEFT SYSTEM

## THE ORIGINAL ANTI-THEFT SYSTEM MLS W 020

- The electromechanical anti-theft system isolates the hydraulics of the vehicle, without altering its original functions
- **It completely locks down the vehicle preventing any movement and therefore the theft**
- To activate the lock, the numbered and irreproducible security key must be removed
- Certified, Approved, Patented



W 020



W 020 JUMBO



# SATELLITE SYSTEMS

NO ANNUAL FEE



## SAT PLUS

### 12/24 V SATELLITE SYSTEM

- Sat Plus 12/24 V is a small tracking device rich of unique functions
- A particular versatile device suitable for various applications, that always guarantees the maximum efficiency (safety and real-time tracking of the vehicles)



## TRACK ME PLUS

### MAGNETIC SATELLITE TRACKER WITH RECHARGEABLE BATTERY

- Track Me Plus is a highly reliable satellite tracker, easily concealable anywhere
- It can operate either with its long-lasting rechargeable battery or by being directly connected to a 12/24 V power supply via any +/- terminals of the vehicle



## iTRACK ME

### INTERCONTINENTAL GSM/WI-FI TRACKER WITH RECHARGEABLE BATTERY (UP TO 12 MONTHS)

- iTrack Me is a portable credit-card size GSM-Wi-Fi tracker, suitable for any use
- It tracks worldwide



# ALARM SYSTEMS



## GYROTRACTOR

### ANTI-ROLLOVER ALARM

- Gyrotractor is an essential accessory for those who often work alone in rural areas
- Connected to the satellite system, the Gyrotractor alarm improves the safety standard during agricultural work and allows a prompt intervention in case of rollover



tractors



telehandlers



construction equipment

## CAP ALARM

### OPENING-CLOSING TANK CAP ALARM

- Cap Alarm is an electromechanical system for real-time monitoring over the opening and closing of the tank cap, with optional syphon prevention feature
- Connected to the satellite system, Cap Alarm documents with time, date and location each refuelling and possible fuel theft



industrial vehicles



buses



generator sets



tractors



telehandlers



construction equipment

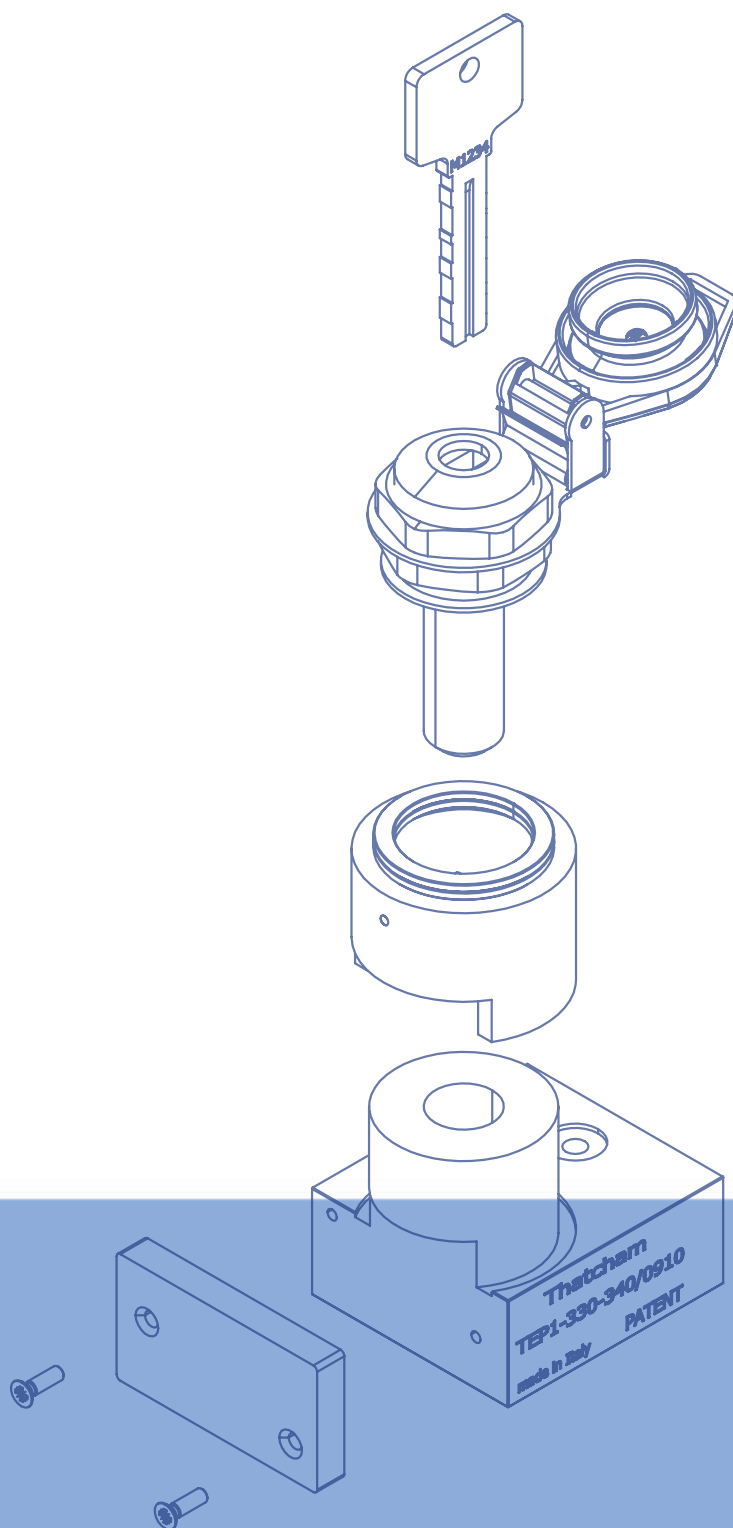

**Mechanical Line Solutions Srl**  
Via Ludovico Ariosto 6 - 20145 Milano (MI)  
Tel. (+39) 0245076781 - info@mlsrl.it

[www.mlsrl.it](http://www.mlsrl.it)